



TECHNICAL DATASHEET

TAB MAGIC TRUCK TM22

ORDER INFORMATION

TAB ID
126612

Short Code
TM22

DIN Marking
72527 SMF

EAN Code
3838807026582

Quantity per EU/CNT pallet
18/24 pcs

TECHNOLOGY

Primary Function
Engine Start

Battery Technology
Flooded

Grid Type (pos/neg)
Casted/Concasted

Grid Alloy (pos/neg)
Ca/Ca

Separator
PE

Electrolyte (g/cm³)
1,28

TECHNICAL INFORMATION

Voltage (V)
12

Capacity C20 (Ah)
225

CCA -18°C EN (A)
1300

RC (min)
469

LxWxH (mm)
514x275x214/241

Total Weight (kg)
56.1

BOX DESIGN

Box Type
C

Cover Type
SMF

Colour
Black

Layout
3

BHD
B0

Terminal
1

DRAWING

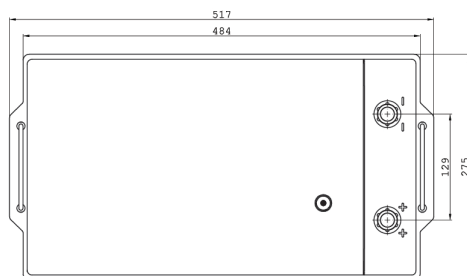
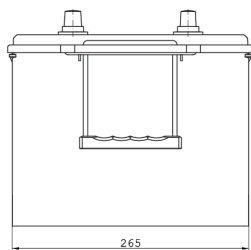
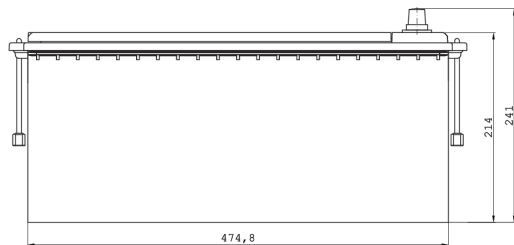

BHD



LAYOUT

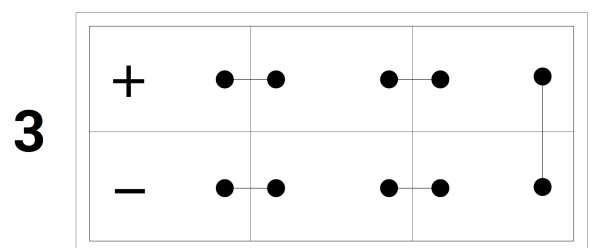

TERMINAL

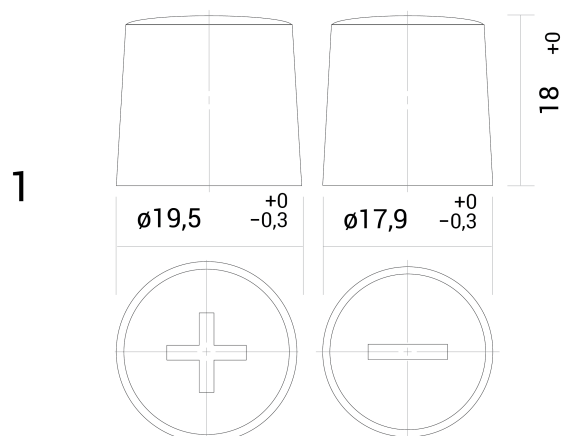

TECHNICAL DATASHEET

TAB MAGIC TRUCK TM22